

8 7 6 5 4 3 2 1

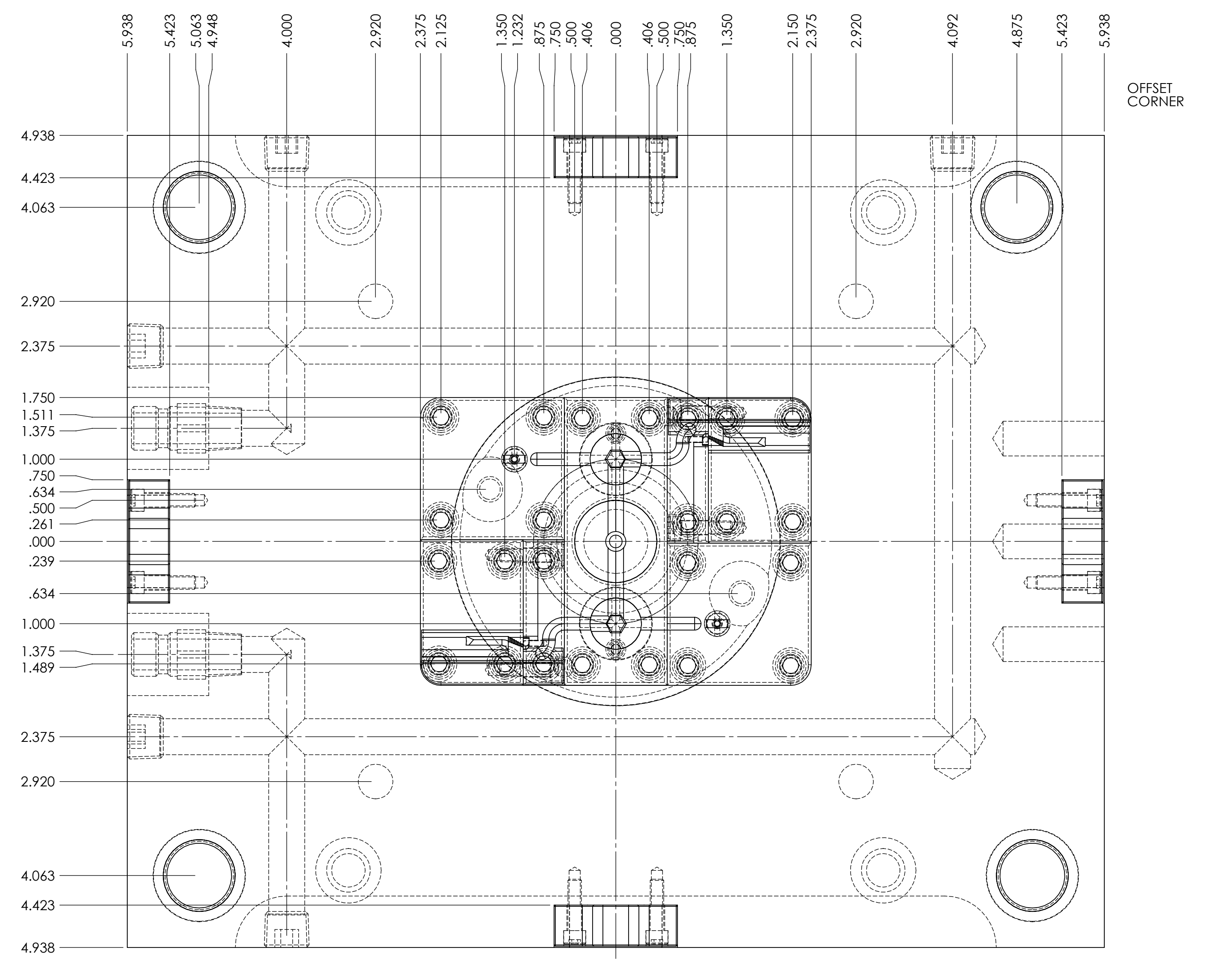

8 7 6 5 4 3 2 1

<p>PROPRIETARY AND CONFIDENTIAL THE INFORMATION CONTAINED IN THIS DRAWING IS THE SOLE PROPERTY OF BUILT RITE TOOL & DIE, INC. ANY REPRODUCTION IN PART OR AS A WHOLE WITHOUT THE WRITTEN PERMISSION OF BUILT RITE TOOL & DIE, INC. IS PROHIBITED.</p>	<p>UNLESS OTHERWISE SPECIFIED: DIMENSIONS ARE IN INCHES TOLERANCES: FRACTIONAL ± 1/64 ANGULAR: ± 1/4° TWO PLACE DECIMAL ± .01 THREE PLACE DECIMAL ± .001</p>	<table border="1"> <tr> <th>NAME</th> <th>DATE</th> </tr> <tr> <td>R_I</td> <td></td> </tr> </table>	NAME	DATE	R_I		TITLE:		
	NAME	DATE							
	R_I								
	<p>INTERPRET GEOMETRIC TOLERANCING PER: MATERIAL: FINISH: DO NOT SCALE DRAWING</p>	<p>Q.A. COMMENTS:</p>	<table border="1"> <tr> <th>SIZE</th> <th>JOB NO.</th> <th>REV</th> </tr> <tr> <td>D</td> <td></td> <td></td> </tr> </table>	SIZE	JOB NO.	REV	D		
SIZE	JOB NO.	REV							
D									
		SHEET 1 OF 9							

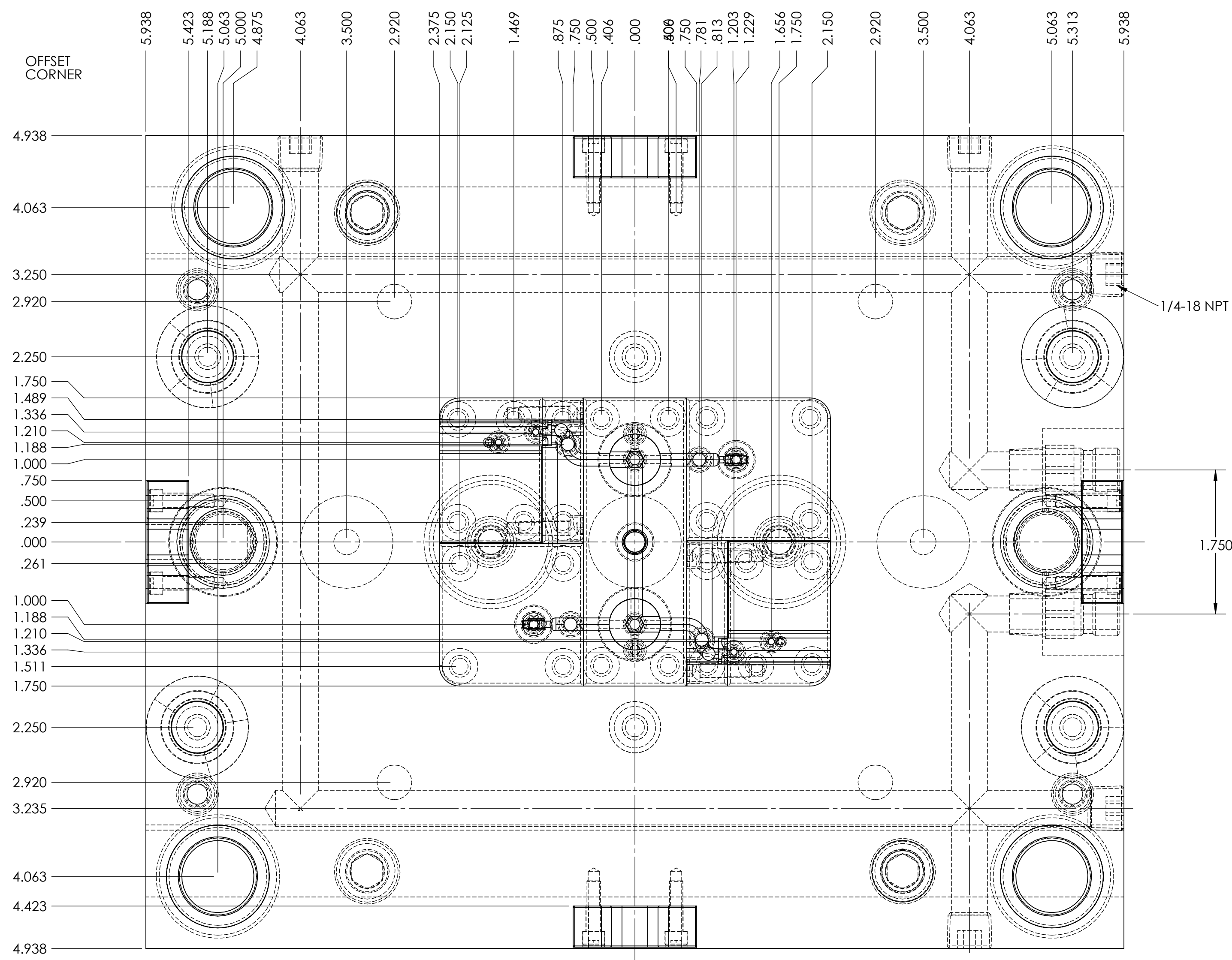
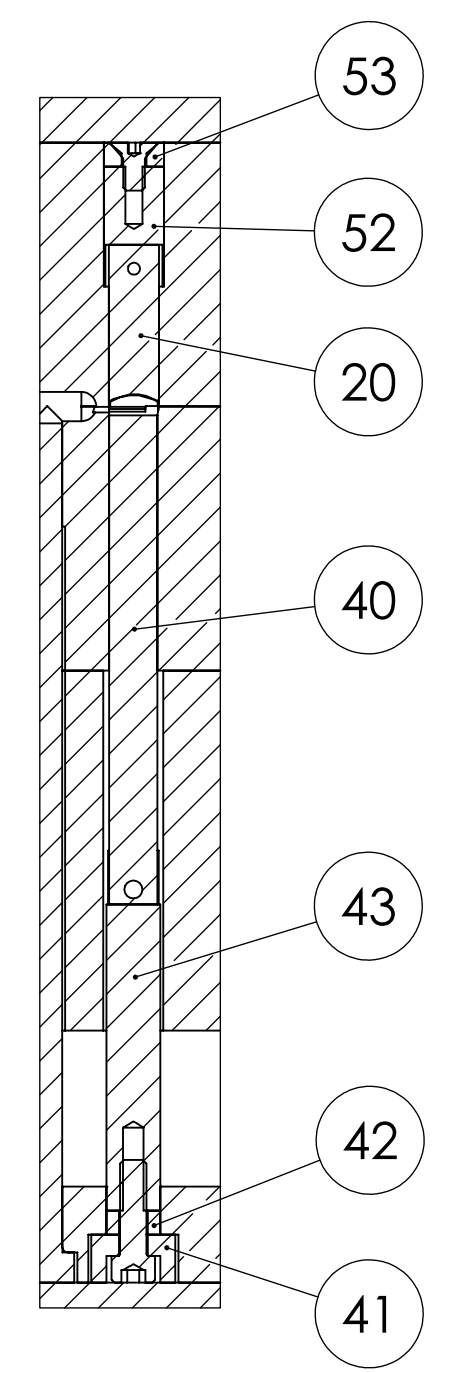
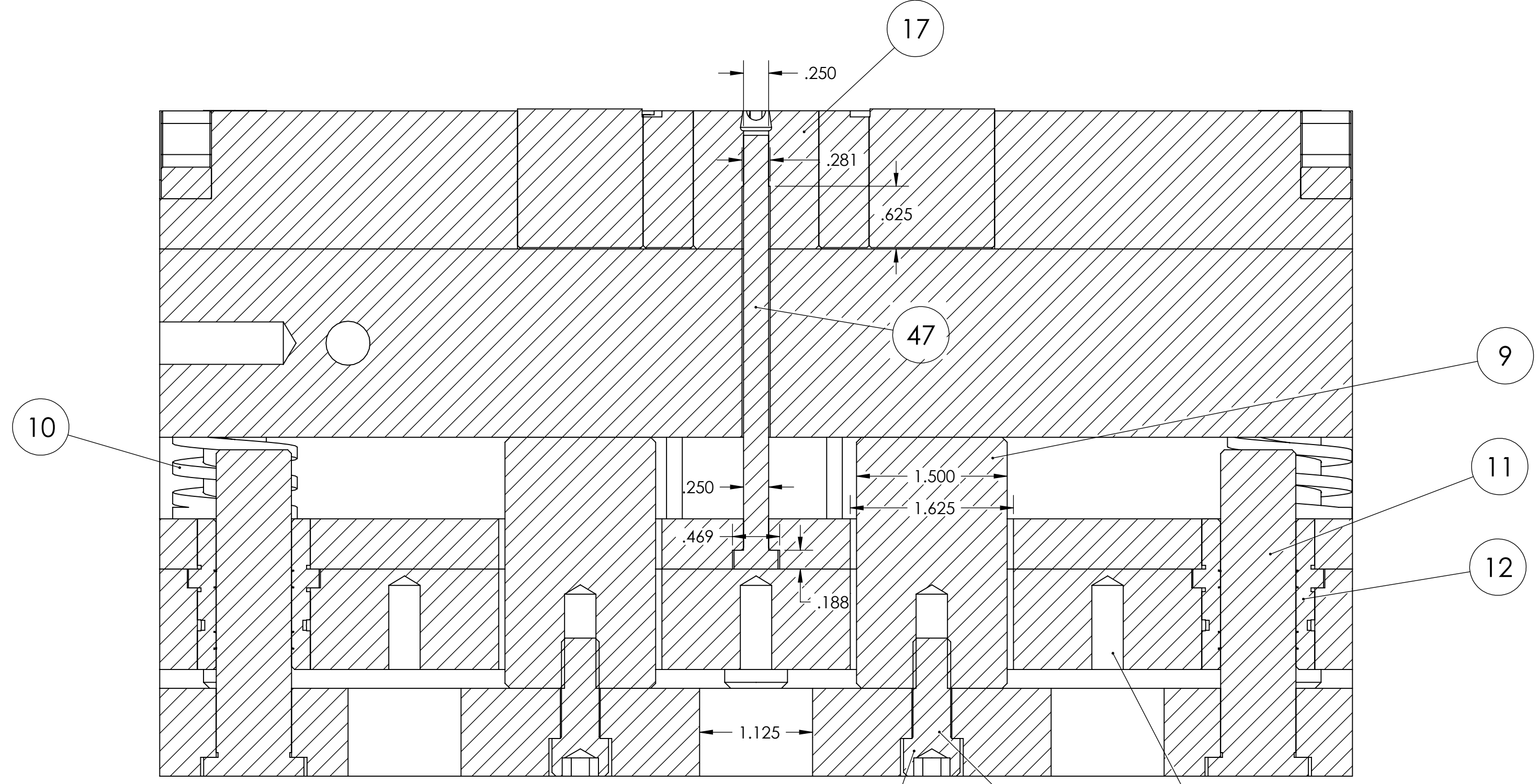
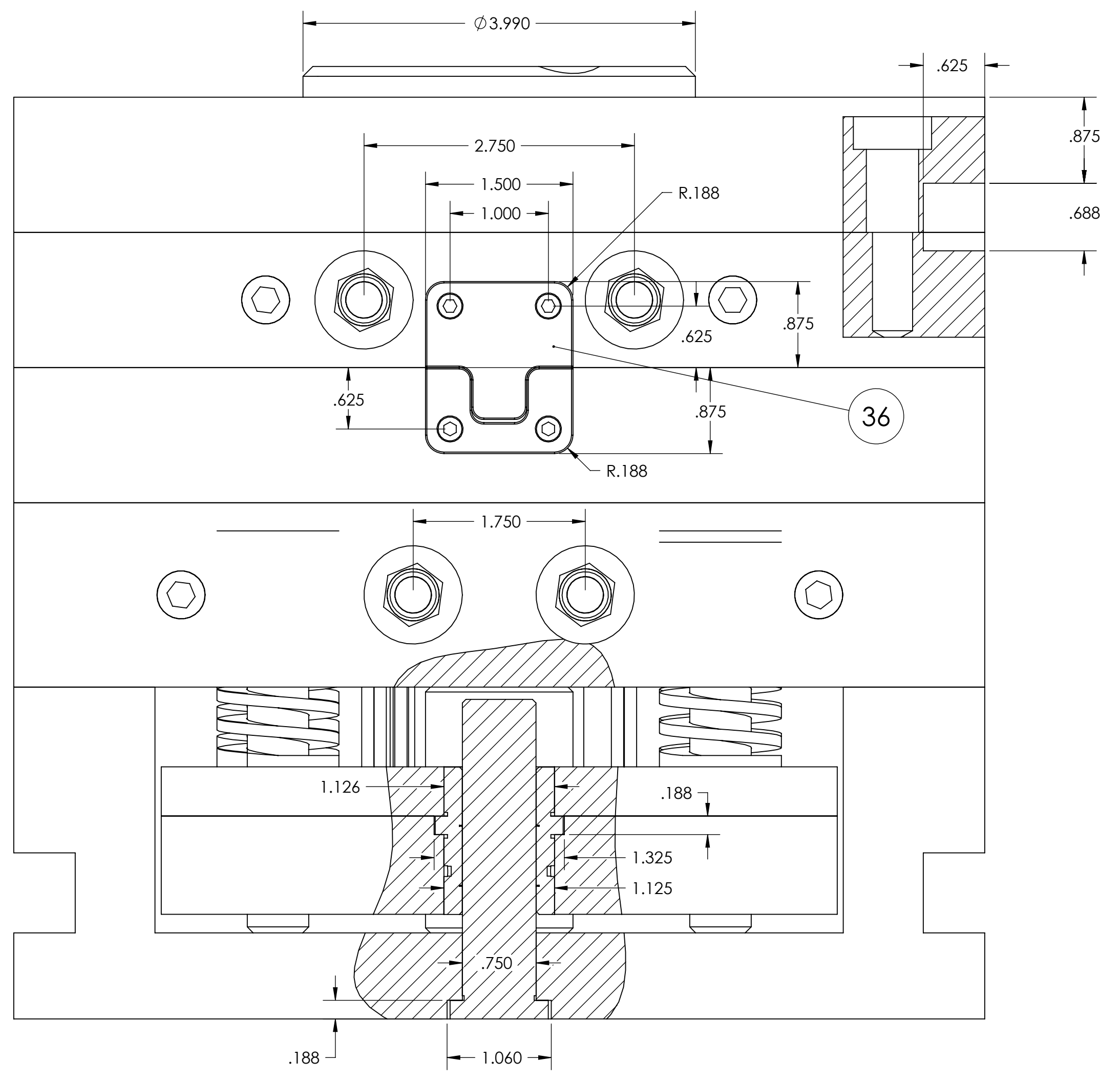
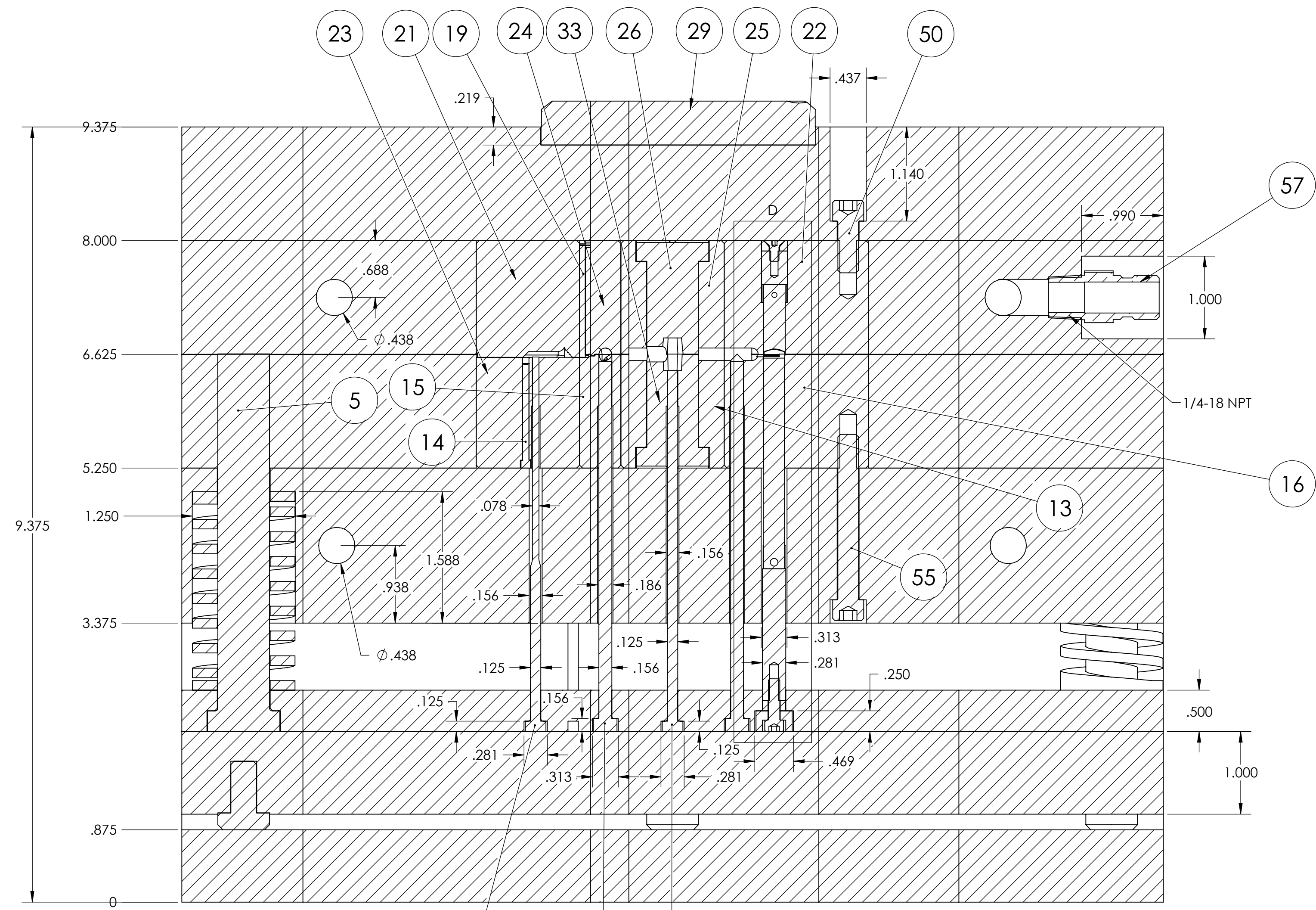

DETAIL D
SCALE 1 : 1

UNLESS OTHERWISE SPECIFIED: DIMENSIONS ARE IN INCHES TOLERANCES: FRACTIONAL: ± 1/64 ANGULAR: ± 1/4° TWO PLACE DECIMAL: ± .01 THREE PLACE DECIMAL: ± .001	DRAWN: R_I CHECKED: ENG APPR: MFG APPR:	NAME: DATE:	TITLE: SIZE: JOB NO. REV SCALE: AS NOTED SHEET 2 OF 9
	COMMENTS:		
	Q.A.:		
	FINISH: DO NOT SCALE DRAWING		

PROPRIETARY AND CONFIDENTIAL
 THE INFORMATION CONTAINED IN THIS
 DRAWING IS THE SOLE PROPERTY OF
 BUILT RITE TOOL & DIE, INC. ANY
 REPRODUCTION IN PART OR AS A WHOLE
 WITHOUT THE WRITTEN PERMISSION OF
 BUILT RITE TOOL & DIE, INC. IS
 PROHIBITED.

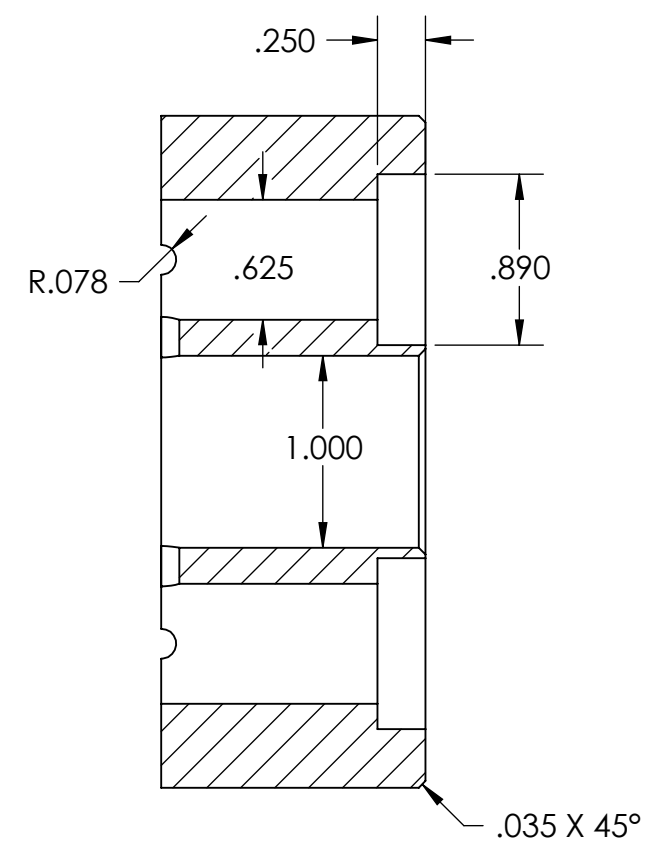
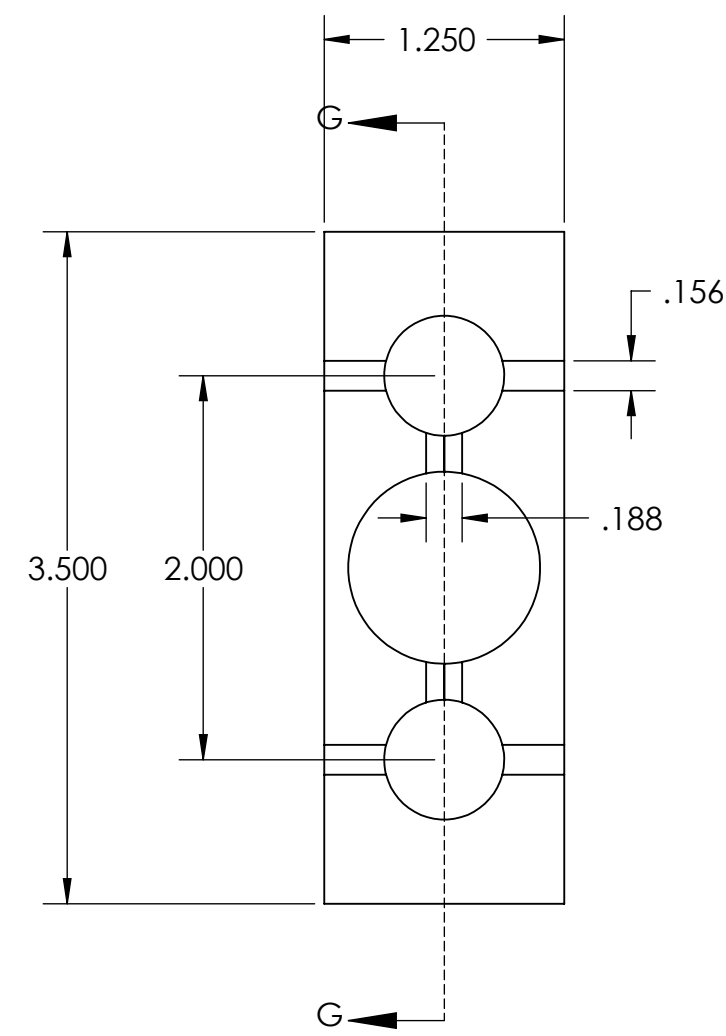

SECTION G-G
SCALE 1:1

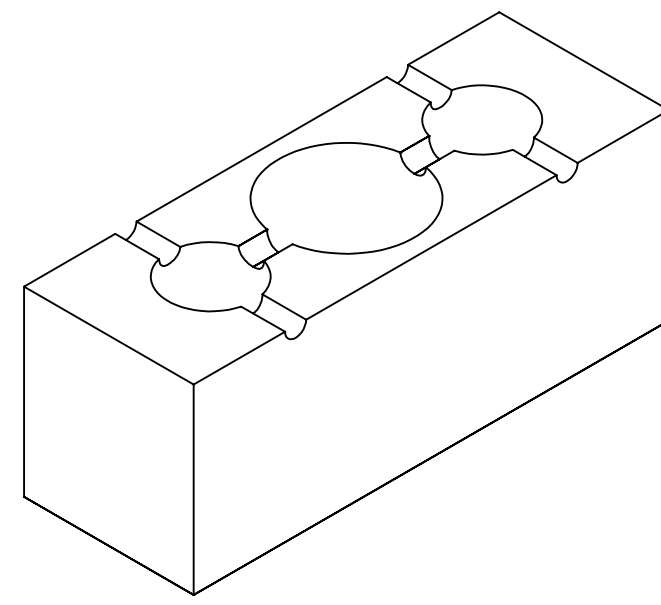

25 CAVITY RUNNER BAR

MATERIAL: S-7
QUANTITY: X
HARDNESS: 50~52 Rc

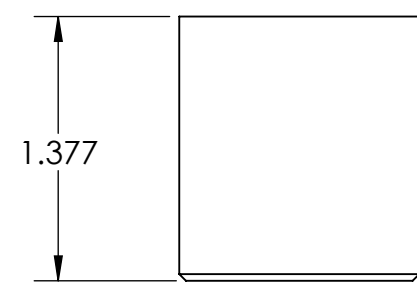

4X ϕ .201 ∇ .650
1/4-20 UNC ∇ .500

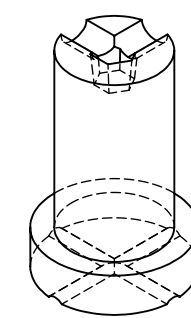
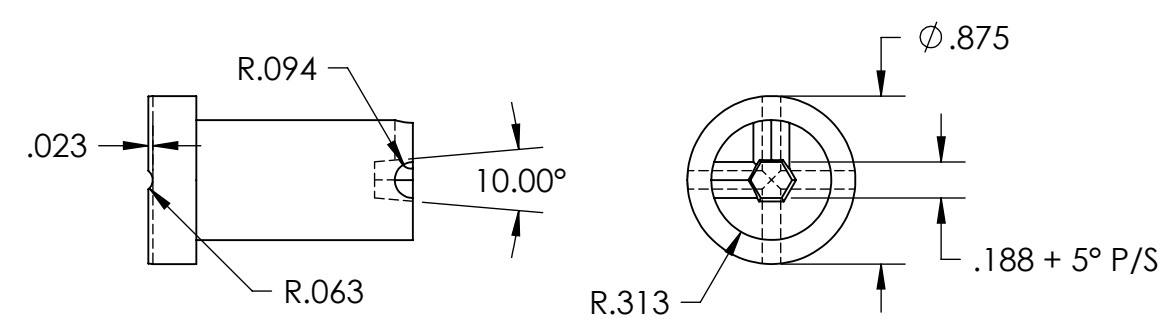
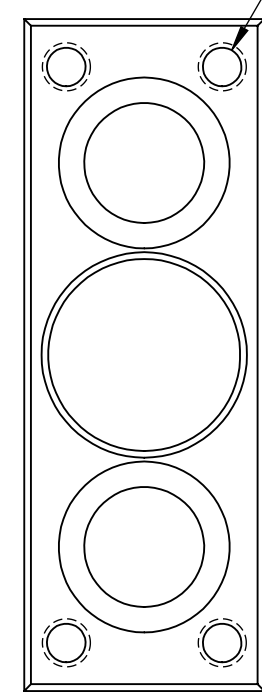

CAVITY RUNNER SHUT-OFF

26 MATERIAL: CX-37 M-6
QUANTITY: 2
HARDNESS: AS SUPPLIED

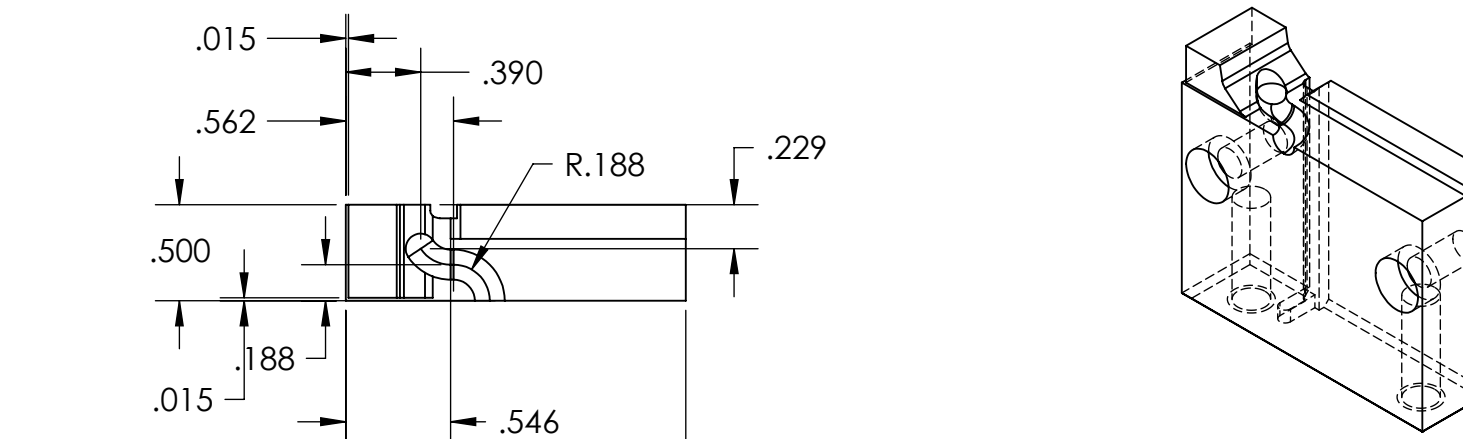
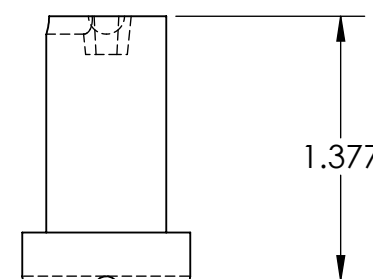

2X ϕ .177 THRU ALL
 ϕ .313 ∇ .164

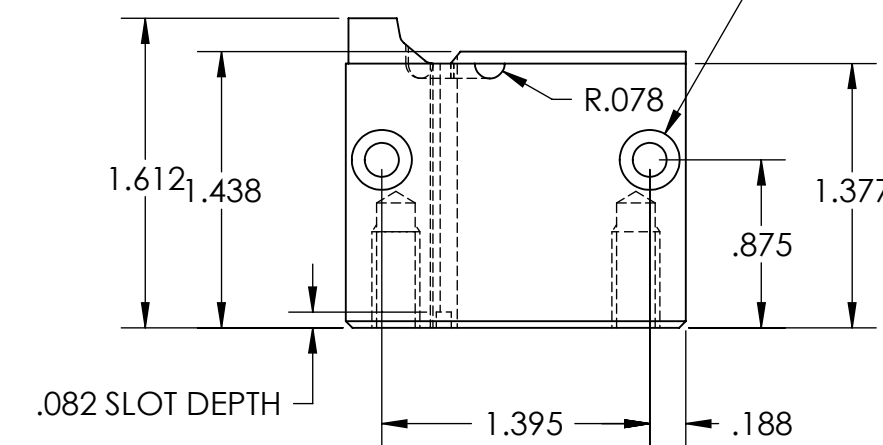

24 MATERIAL: 420 SS
QUANTITY: 2
HARDNESS: 48~50 Rc

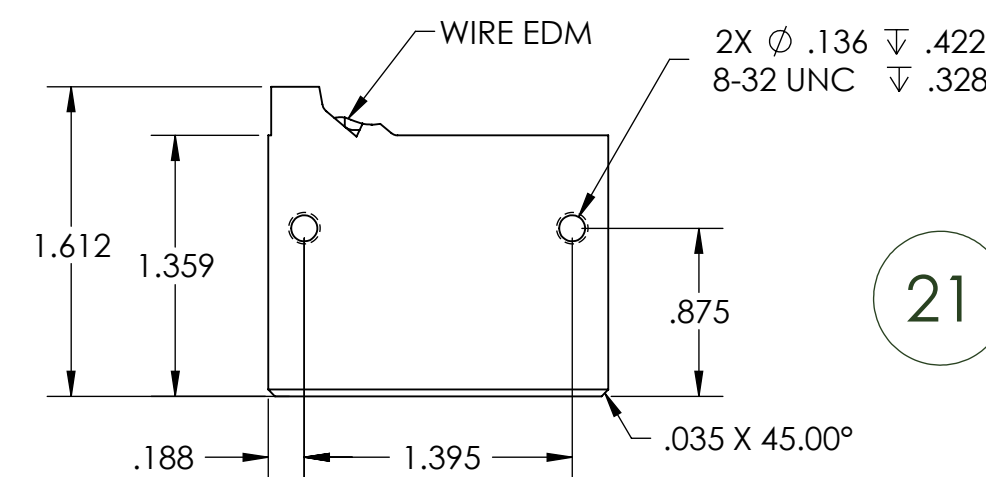
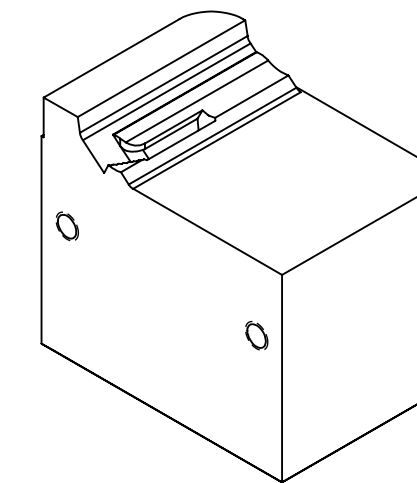
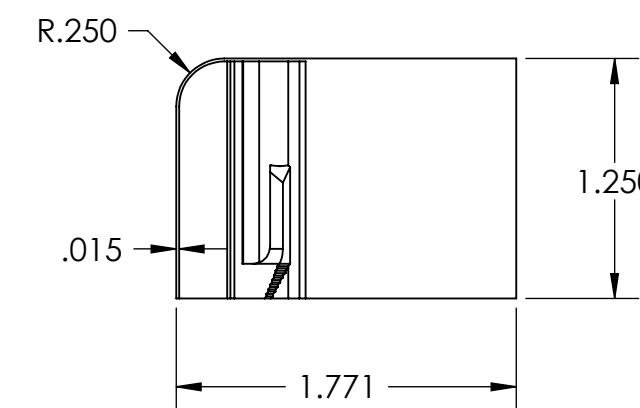
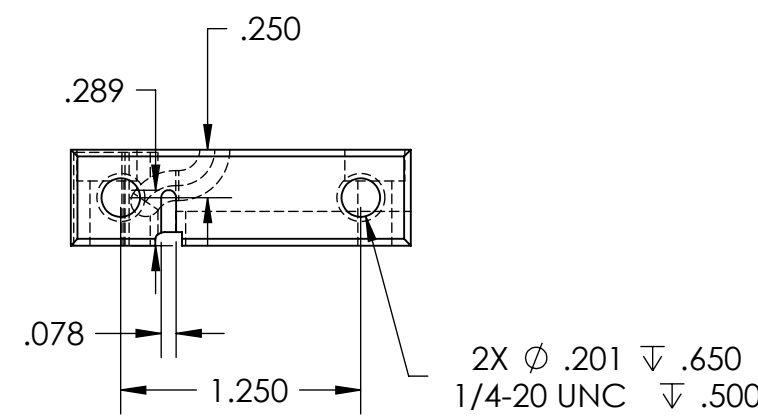

21 ILLUMINATOR CAVITY-LARGE INSERT
MATERIAL: 420 SS
QUANTITY: 2
HARDNESS: 48~50 Rc

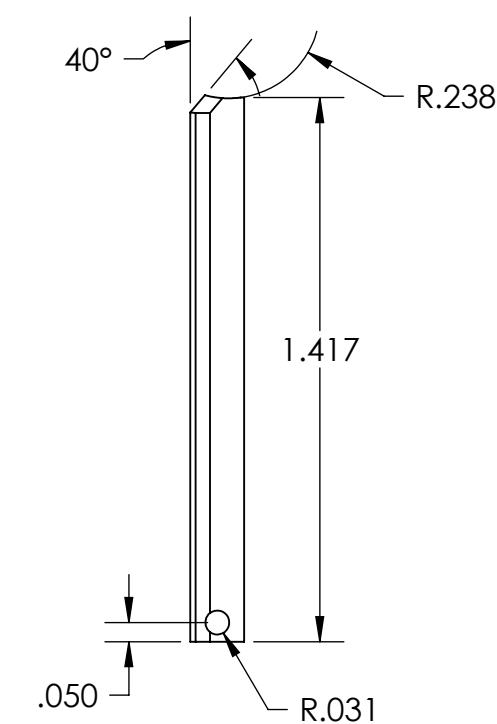
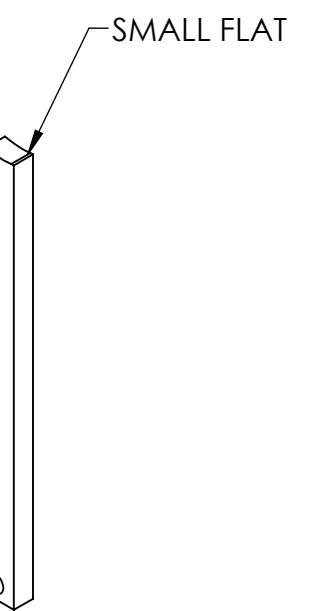
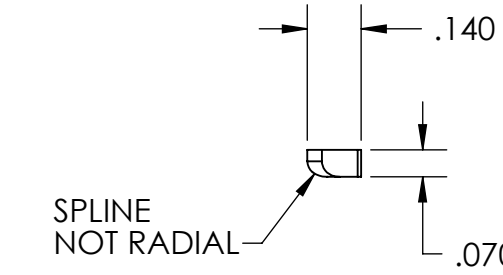
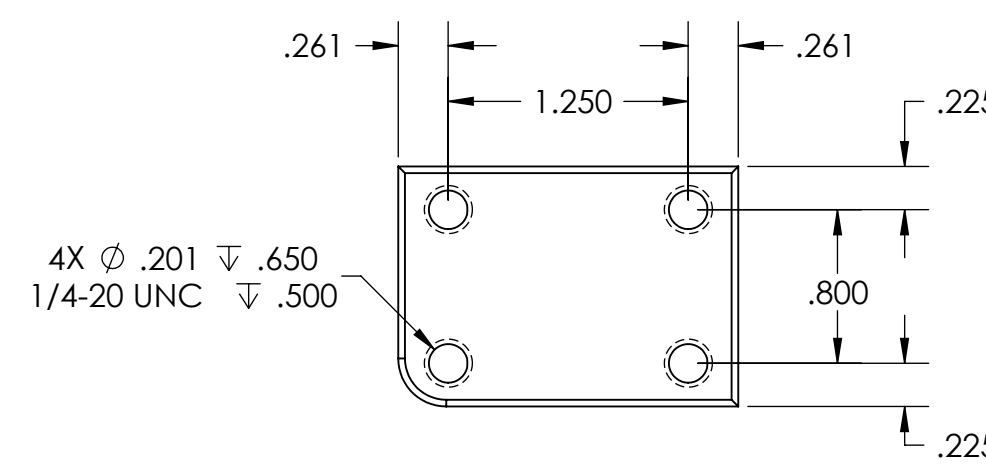

ILLUMINATOR-INSERT-CAVITY

19 MATERIAL: S-7
QUANTITY: 2
HARDNESS: 50~52 Rc

PROPRIETARY AND CONFIDENTIAL
THE INFORMATION CONTAINED IN THIS DRAWING IS THE SOLE PROPERTY OF BUILT RITE TOOL & DIE, INC. ANY REPRODUCTION IN PART OR AS A WHOLE WITHOUT THE WRITTEN PERMISSION OF BUILT RITE TOOL & DIE, INC. IS PROHIBITED.

UNLESS OTHERWISE SPECIFIED:	DRAWN	NAME	DATE
DIMENSIONS ARE IN INCHES	R_1		
TOLERANCES:	CHECKED		
FRACTIONAL: \pm 1/64	ENG APPR:		
ANGULAR: \pm 1/4°	MFG APPR:		
TWO PLACE DECIMAL: \pm .01	Q.A.		
THREE PLACE DECIMAL: \pm .001	COMMENTS:		
FINISH			
DO NOT SCALE DRAWING			

SIZE	JOB NO.	REV
D		
SCALE: AS NOTED	SHEET 6 OF 9	